

Q3450/Q3453A,B,C,D,E,F,G and Q3480B,C SmartValve™ System Pilot Burners

PRODUCT DATA



APPLICATION

These SmartValve™ System pilot burners provide pilot flame ignition and sensing for SV95XX/SV96XX Systems. They consist of replaceable igniter-flame rod assembly, bracket assembly, pilot target, ground electrode, orifice assembly, compression fitting and spring clip. The igniter lights the pilot burner. The flame rod proves the pilot flame and the pilot flame lights the main burner.

FEATURES

- Used with SV95XX/SV96XX SmartValve™ System.
- Replaceable Igniter-Flame Rod Assembly (Q3400A).
- Replaceable igniter-Flame Rod Assembly for SV958X (Q3405A).
- Integral keyed plug provides quick, convenient connection of igniter and sensor to SV95XX/SV96XX.
- Q3450/Q3453 has front or 20 degree right, left flame pattern.
- Q3480 has dual-wing flame pattern.
- Natural and LP gas orifices available.
- Variety of target styles available.

Contents

Application	1
Features	1
Specifications	2
Ordering Information	2
Installation	6
Service	7



SPECIFICATIONS

IMPORTANT

The specifications given in this publication do not include normal manufacturing tolerances. Therefore, this unit may not exactly match the listed specifications. Also, this product is tested and calibrated under closely controlled conditions, and some minor differences in performance can be expected if those conditions are changed.

Models:

Q3450/Q3453A,B,C,D,E,F,G and Q3480B,C SmartValve™ System Pilot Burner. See Table 1 for model specifications.

Table 1. Model Specifications.

Models	Type of Gas	Target Style	Standard Orifice
Q3450, Q3453	Natural/LP	L, F, K	BCR18 (P/N 390686-4) BBR11 (P/N 390686-36)
Q3480	Natural/LP	Dual-wing	NE22 (P/N 388146NE) KR14 (P/N 388146KP)

Target Styles and Flame Patterns: Refer to Fig. 1.

Mounting Brackets and Dimensions: Refer to Fig. 2 through 4.

Type of Gas: Models available for Natural and LP gas.

Maximum Temperature Ratings:

- Ground Electrode Tip: 1800°F (982°C).
- Target Tip: 1575°F (857°C).
- Orifice: 800°F (427°C).
- Flame Rod Tip: 1800°F (982°C).
- Igniter Insulator: 905°F (485°C).
- Flame Rod Insulator: 1250°F (677°C).

Electrode Flame Rod Material: Kanthal.

Wiring Connection: 18-inch integral keyed connector for attaching to SV9500/SV9600.

Approvals:

American Gas Association design certified: U70-24A
 Canadian Gas Association design certified:
 1029-ABI/CC-9203

Accessory: Q3400A Replacement Igniter-Flame Rod Assembly.

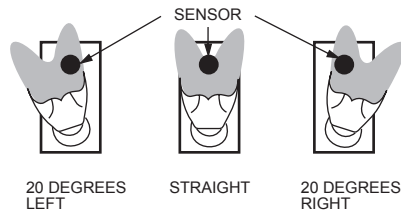

Q3450/Q3453

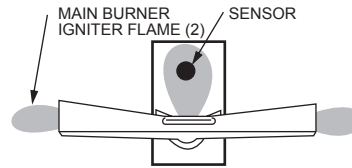

Q3480

M9052A

Fig. 1. Pilot burner/igniter sensor target styles and flame patterns.

ORDERING INFORMATION

When purchasing replacement and modernization products from your TRADELINE® wholesaler or distributor, refer to the TRADELINE® Catalog or price sheets for complete ordering number.

If you have additional questions, need further information, or would like to comment on our products or services, please write or phone:

1. Your local Honeywell Automation and Control Products Sales Office (check white pages of your phone directory).
2. Honeywell Customer Care
 1885 Douglas Drive North
 Minneapolis, Minnesota 55422-4386

In Canada—Honeywell Limited/Honeywell Limitée, 35 Dynamic Drive, Scarborough, Ontario M1V 4Z9.

International Sales and Service Offices in all principal cities of the world. Manufacturing in Australia, Canada, Finland, France, Germany, Japan, Mexico, Netherlands, Spain, Taiwan, United Kingdom, U.S.A.

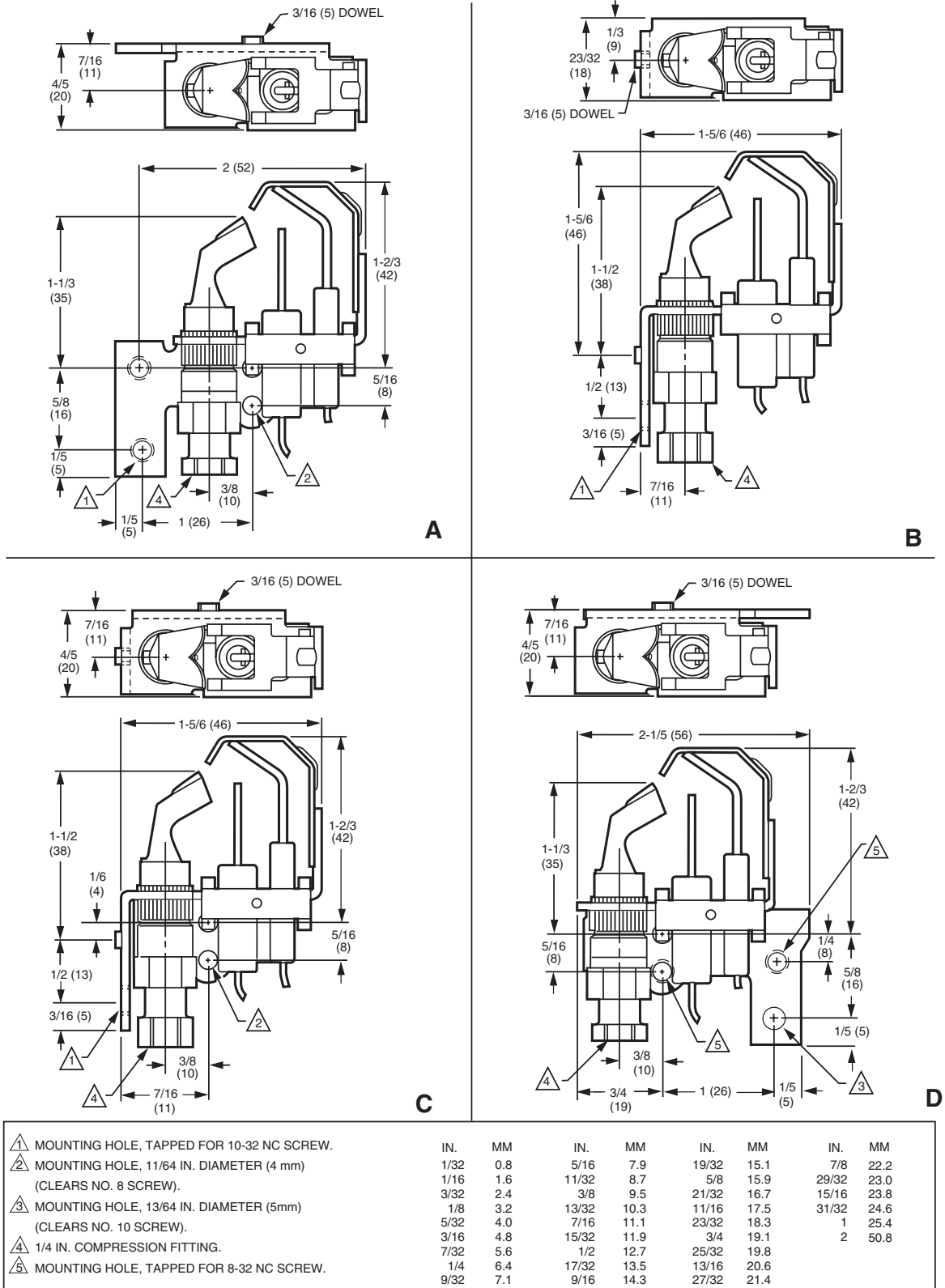
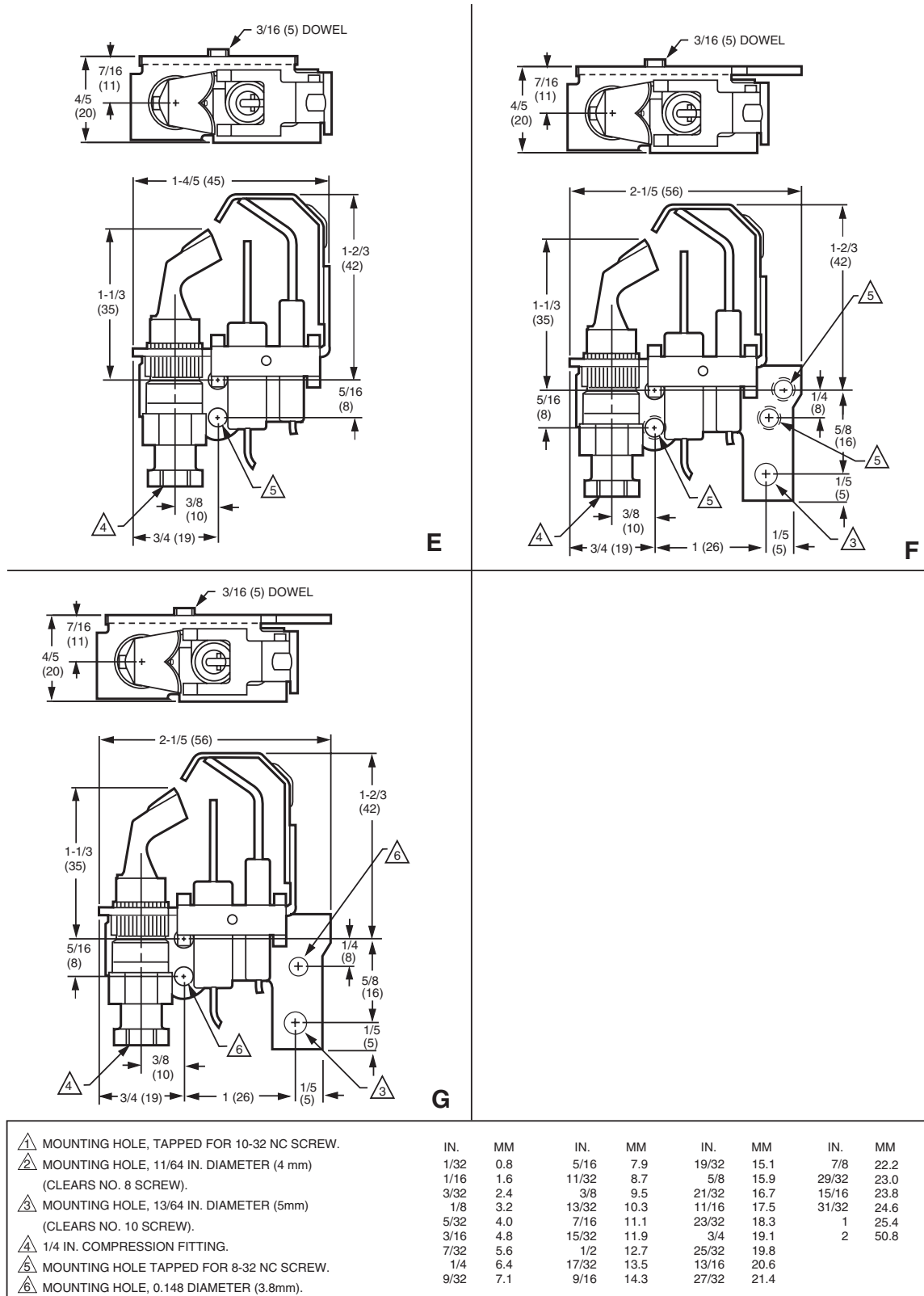
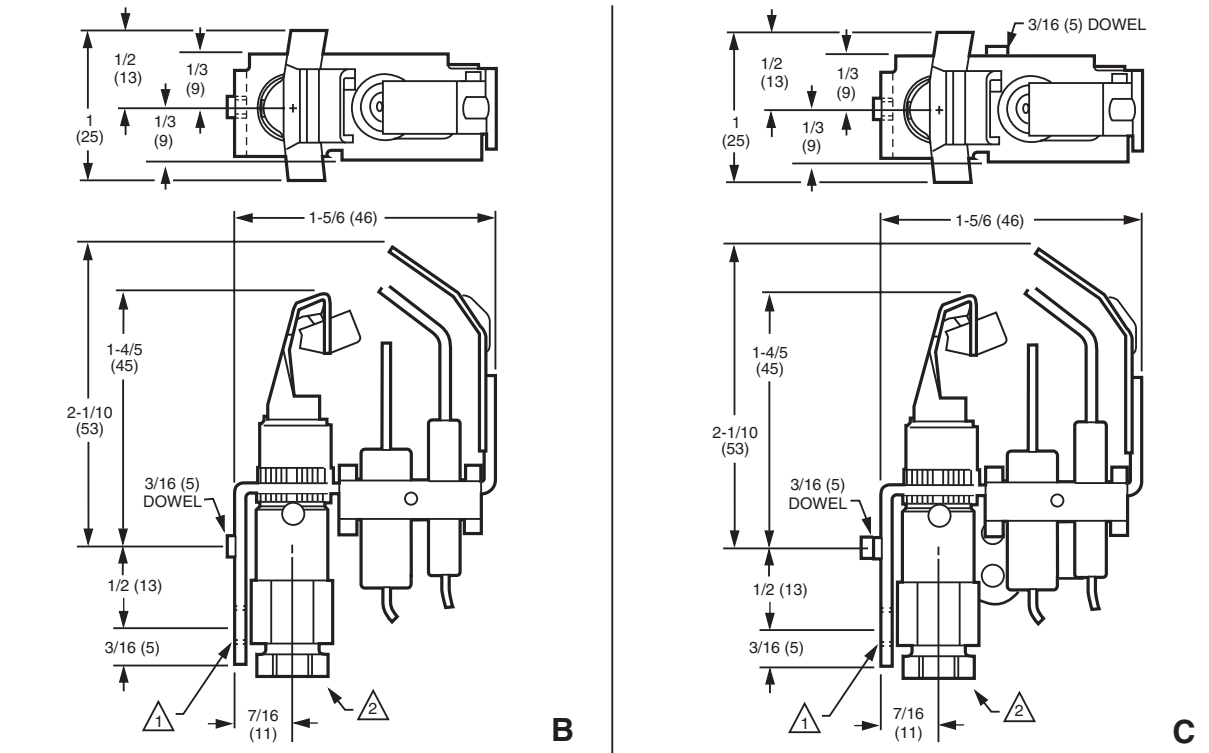

Fig. 2. Mounting bracket dimensions for Q3450/Q3453A,B,C and D.



M9587A

Fig. 3. Mounting bracket dimensions for Q3450/Q3453E,F,G.



▲ MOUNTING HOLE, TAPPED FOR 10-32 SCREW.	IN.	MM	IN.	MM	IN.	MM	IN.	MM
▲ 1/4 IN. COMPRESSION FITTING.	1/32	0.8	5/16	7.9	19/32	15.1	7/8	22.2
	1/16	1.6	11/32	8.7	5/8	15.9	29/32	23.0
	3/32	2.4	3/8	9.5	21/32	16.7	15/16	23.8
	1/8	3.2	13/32	10.3	11/16	17.5	31/32	24.6
	5/32	4.0	7/16	11.1	23/32	18.3	1	25.4
	3/16	4.8	15/32	11.9	3/4	19.1	2	50.8
	7/32	5.6	1/2	12.7	25/32	19.8		
	1/4	6.4	17/32	13.5	13/16	20.6		
	9/32	7.1	9/16	14.3	27/32	21.4		

M9588A

Fig. 4. Mounting bracket dimensions for Q3480B,C.

INSTALLATION

When Installing this Product...

1. Read these instructions carefully. Failure to follow instructions can damage product or cause a hazardous condition.
2. Check ratings given in instructions and on product to make sure product is suitable for your application.
3. Make sure installer is a trained, experienced service technician.
4. After completing installation, use these instructions to check out product operation.

⚠ WARNING

Fire or Explosion Hazard.
Can cause severe injury, death or property damage.

Follow these warnings exactly:

1. Disconnect power supply before wiring to prevent electrical shock or equipment damage.
2. To avoid dangerous accumulation of fuel gas, turn off gas supply at appliance service valve before starting installation and perform Gas Leak Test after completion of installation.
3. Do not bend pilot tubing at the control or pilot after compression nut is tightened. Gas leakage at the connection may result.

Follow appliance manufacturer instructions if available; otherwise, use instructions provided below.

Location

1. Position the pilot burner for easy access and observation. In replacement applications, replace the pilot burner with an identical unit and position the new pilot burner in the same location and orientation as the original pilot burner.
2. Mount the pilot burner on the main burner. Mounting surfaces other than the main burner can shift, bend, or warp as the furnace expands and contracts while operating. See Fig. 5.

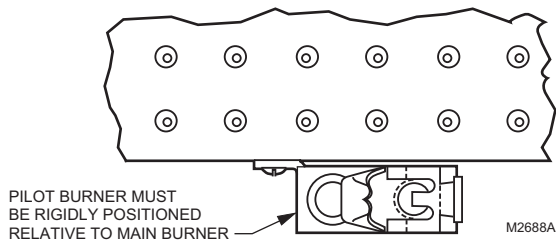

Fig. 5. Mount pilot burner on main burner.

3. Mount the pilot burner so the pilot flame remains properly positioned with respect to the main burner flame. See Fig. 6.
4. Supply pilot flame with ample air which is free of combustion products.

5. Do not impinge pilot flame on adjacent parts. Do not impinge main burner flame on pilot burner.
6. Do not expose the pilot flame to falling scale that could impair the main burner ignition.

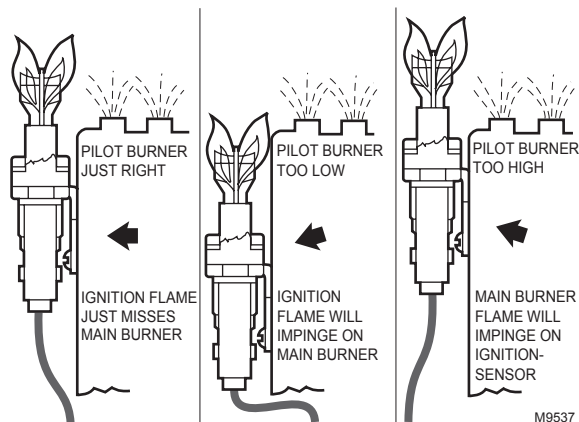

Fig. 6. Location of pilot burner.

7. Do not expose the pilot burner to main burner rollout while igniting or extinguishing.
8. Do not expose the pilot flame to drafts that push or pull the pilot flame away from the igniter-flame rod.

Connect Pilot Gas Tubing

1. Cut tubing to the desired length and bend as necessary for routing to the pilot burner. Do not make sharp bends or deform tubing. Do not bend tubing at control after compression nut is tightened because this can result in gas leakage at connection.
2. Square off and remove burrs from the end of the tubing.
3. Push tubing into compression nut clearance hole until tubing bottoms.

NOTE: When replacing SmartValve™ System control, cut off the old compression fitting and replace it with a new compression fitting provided with the new pilot burner. Never use the old compression fitting because it might not provide a gas-tight seal. See Fig. 7.

4. While holding the tubing all the way in, engage threads and turn until finger tight.
5. Using a wrench, turn compression nut one turn beyond finger tight. Do not overtighten.
6. Connect the other end of the tubing to the ignition system control according to the ignition system control manufacturer instructions.

Wire Pilot Burner to Ignition System Control

1. Mount the igniter-flame rod assembly on the pilot burner.
2. Connect the igniter-flame rod assembly keyed plug connector to its mating terminal block labeled IGNITER on the SV9500/SV9600.
3. Use ceramic or plastic standoff insulators as necessary to prevent cable from contacting metal surfaces.

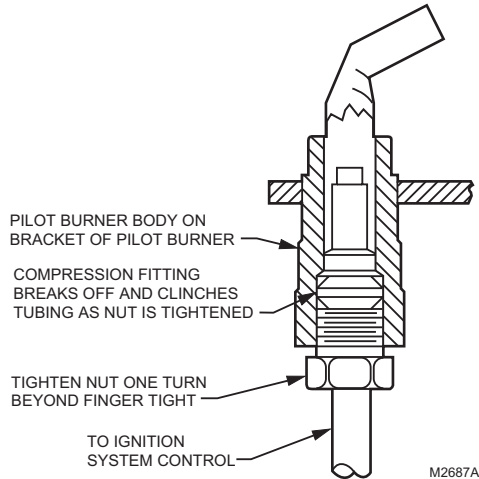

Fig. 7. Always use the new compression fitting.

STARTUP AND CHECKOUT

Perform Gas Leak Test

⚠ WARNING

Fire or Explosion Hazard.
Can cause severe injury, death or property damage.

Check for gas leaks with soap and water solution any time work is done on a gas system.

Gas Leak Test:

1. Make sure the gas supply is turned on at the appliance service valve.
2. Paint pipe connections upstream of pilot burner with rich soap and water solution. Bubbles indicate a gas leak.
3. If a leak is detected, tighten the pipe connections.
4. Set the thermostat to call for heat to light the main burner.
5. With the main burner in operation, paint pipe joints (including adapters) and SV9500/SV9600 control inlet and outlet with rich soap and water solution.
6. If another gas leak is detected, tighten adapter screws, joints, and pipe connections.
7. Replace part if leak cannot be stopped.

Adjust Pilot Flame

The pilot flame should envelop approximately 3/8 in. (10 mm) of the sensor tip. See Fig. 8.

To adjust pilot flame:

1. Turn off system by setting thermostat below the temperature to call for heat.
2. Disconnect lead to MV terminal on SV9500/SV9600.
3. Light pilot by setting the thermostat to call for heat.
4. Remove pilot adjustment cover screw from gas control.
5. Turn inner pilot adjustment screw clockwise to decrease or counterclockwise to increase pilot flame.

6. Always replace pilot adjustment cover screw and tighten firmly after completing adjustment to assure proper operation.

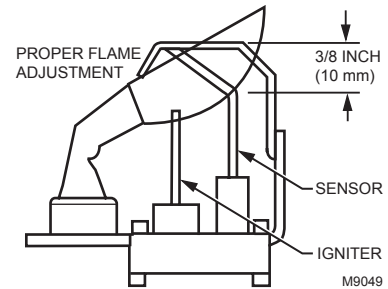

Fig. 8. Sensor tip must be in pilot flame.

SERVICE

⚠ WARNING

Fire or Explosion Hazard.
Can cause severe injury, death or property damage.

Perform Gas Leak Test any time work is done to the system.

Pilot Outage

1. If pilot flame goes out during ignition, but is properly adjusted, recheck mounting and location instructions in Location section.
2. If all mounting and location instructions are followed but the pilot continues to go out, construct a shield to protect the pilot flame from the main burner ignition, extinction and drafts. See Fig. 9

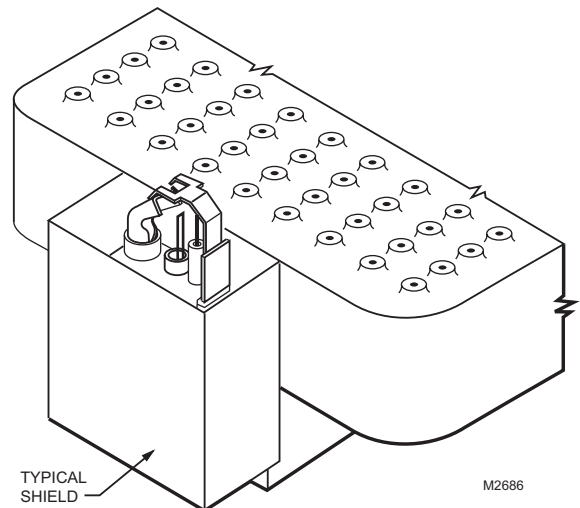

Fig. 9. Proper shielding of pilot flame.

3. Check pilot and main burner lightoff.
 - a. Set the thermostat to call for heat.
 - b. Watch the pilot burner during the ignition sequence to determine if:

- (1) Igniter continues to glow red after the pilot is lit.
 - (2) The pilot lights and the igniter stops glowing red, but main burner does not light.
- a. If pilot burner is functioning correctly, ensure adequate flame current as follows:
- (1) Turn off the furnace at the circuit breaker or fuse box.
 - (2) Clean the flame rod with an emery cloth.
 - (3) Make sure electrical connections are clean and tight.
 - (4) Check for cracked ceramic insulator, which can cause short to ground, and replace igniter-flame rod assembly if necessary.
 - (5) Turn on power and set thermostat to call for heat. The pilot should light and then the main burner should light.

6. Connect igniter-flame rod assembly keyed plug to igniter connection on the SV9500/SV9600.
7. Turn on power and set the thermostat to call for heat. The pilot should light and then the main burner should light.

Check Ignition Cable

1. Make sure that ignition cable is not in contact with metal surfaces.
2. Make sure that ignition cable is not more than 3 ft (1m) long.
3. Check electrical continuity of ignition cable.

Check Grounding

1. If ground is poor or erratic, safety shutdown will occur. Therefore, if frequent shutdowns are reported, check that ground is made through the pilot tubing.
2. Excessive temperature at the ceramic flame rod insulator will permit electrical leakage to ground.
 - a. If bracket is bent, bend it back to correct position.
 - b. If insulator is cracked, replace igniter-flame rod assembly (Q3400A or Q3405A for SV9580/SV9581).

Replace Igniter-Flame Rod Assembly

1. Turn off the furnace at the circuit breaker or fuse box.
2. Remove the spring clip, then the igniter-flame rod assembly from the pilot burner.
3. Disconnect the igniter-flame rod assembly keyed plug from the igniter connection on the SV9500/SV9600.
4. Remove the igniter-flame rod assembly from the furnace.
5. Install replacement igniter-flame rod assembly in the pilot burner and secure it with the spring clip.

Honeywell

Automation and Control Solutions

Honeywell International Inc.	Honeywell Limited-Honeywell Limitée
1985 Douglas Drive North	35 Dynamic Drive
Golden Valley, MN 55422	Scarborough, Ontario
	M1V 4Z9

