

T7079A,B Solid State Remote Temperature Controllers

PRODUCT DATA



FEATURES

- Switch selection of heat or cool mode.
- Temperature sensing up to 400 feet.
- Does not require field calibration.
- 10K NTC temperature sensor.
- Wide setpoint temperature range.
- LED annunciation for both power on and relay state.
- Dual setpoint scale (°F and °C).
- Isolation transformer for 24 Vac input.
- Single- or Dual-stage output.
- Dual-stage output models can be configured as two-heat, two-cool, or one-heat/one-cool.

APPLICATION

The T7079 Electronic Remote Sensor Temperature Controller is capable of providing on-off temperature control for ducts, tanks, heating and refrigeration units, greenhouses, animal confinement buildings and other applications where electronic accuracy in addition to remote sensing is desired.

Contents

Application	1
Features	1
Specifications	2
Ordering Information	2
Installation	3
Wiring	4
Operation	5
Checkout	6

SPECIFICATIONS

Models:

T7079: On-off wall-mount control with one temperature input and one or two relay output stages. Differential range of 1 to 30°F. Includes one sensor. See Table 1.

Table 1. T7079 Models.

	Voltage (in Vac)		Setpoint Range in °F (°C)	
	24	120/230	-25 to 105 (-32 to 40)	100 to 240 (38 to 116)
T7079A1004	X		X	
T7079A1012	X			X
T7079A1046		X	X	
T7079A1053		X		X
T7079B1028	X		X	
T7079B1036	X			X
T7079B1044		X	X	
T7079B1051		X		X

Dimensions: See Fig. 1.

Electrical Ratings:

Voltage Input: 24 Vac, 50/60 Hz (+10%, -15%), Class 2 *only*.
120/230 Vac, 50/60 Hz (+10%, -15%).

Power Consumption: See Table 2.

Contact Ratings:

- At 120 Vac: 1/2 hp, 9.8 FLA, 58.8 LRA.
- At 230 Vac: 1/4 hp, 4.9 FLA, 29.4 LRA.
- At 120/230 Vac: 125 VA pilot duty.
- At 24 Vac (resistive): 8A.

Ambient Ratings:

Operating Temperature: -40° to 140°F (-40° to 60°C).
Storage Temperature: -40° to 180°F (-40° to 82°C).
Operating Humidity: 5% to 95% RH non condensing.

Temperature Accuracy (at nominal voltage): In 77°F (25°C) ambient, nominal sensor value: ±2°F.

NOTE: Accuracy can vary based on deviation from nominal values of input voltage, operating ambient and sensor ambient.

Sensor: 10k NTC, 4.8 ohm/°F, 400 ft maximum distance between sensor and electronic controller.

Table 2. Power Consumption Ratings.

Voltage	Hz	Nominal VA	Maximum VA
24	50	5.6	6.2
	60	5.5	6.1
120	50	7.7	8.5
	60	5.6	6.2
230	50	5.0	6.1
	60	2.9	4.7

Approvals:

Underwriters Laboratories, Inc.
Canadian Underwriters Laboratories.
CE.

Accessories:

- 107048 Heat Conduction Compound, 4 once.
- 107324A Bulb Holder, duct insertion.
- 121371A Copper Immersion Well.
- 121371E Stainless Steel Well.
- 32004800-001 10K NTC Sensor.
- T7047C1090 Wall Mounted Sensor Case.

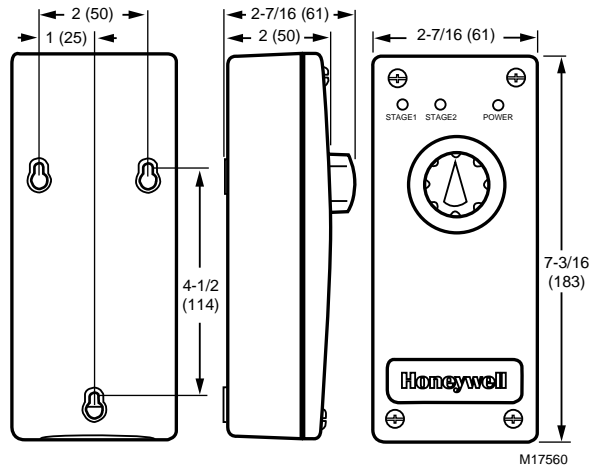

Fig. 1. Dimensions of T7079 in in. (mm).

ORDERING INFORMATION

When purchasing replacement and modernization products from your TRADELINE® wholesaler or distributor, refer to the TRADELINE® Catalog or price sheets for complete ordering number.

If you have additional questions, need further information, or would like to comment on our products or services, please write or phone:

1. Your local Honeywell Automation and Control Products Sales Office (check white pages of your phone directory).
2. Honeywell Customer Care
1885 Douglas Drive North
Minneapolis, Minnesota 55422-4386

In Canada—Honeywell Limited/Honeywell Limitée, 35 Dynamic Drive, Scarborough, Ontario M1V 4Z9.

International Sales and Service Offices in all principal cities of the world. Manufacturing in Australia, Canada, Finland, France, Germany, Japan, Mexico, Netherlands, Spain, Taiwan, United Kingdom, U.S.A.

INSTALLATION

When Installing this Product...

1. Read these instructions carefully. Failure to follow them could damage the product or cause a hazardous condition.
2. Check the ratings given in the instructions and on the product to make sure the product is suitable for your application.
3. Installer must be a trained, experienced service technician.
4. After installation is complete, check out product operation as provided in these instructions.

IMPORTANT

All wiring must agree with applicable codes, ordinances and regulations.



CAUTION

Electrical Shock or Equipment Damage Hazard. Can shock individuals or short equipment circuitry.

Disconnect power supply before installation.

Location and Mounting

Mount the controller on a convenient interior location using the three mounting holes provided on the back of the enclosure (mounting screws are not provided and must be obtained separately). Use controller dimensions in Fig. 1 as a guide.

Sensor Location

The sensor can be located up to 400 feet (122 meters) from the T7079 using standard AWG 18/2 unshielded wire. The sensor may be attached to pipes, in an immersion well, in a wall-mounted case or on a bulb holder.

NOTES:

- For cable runs greater than 25 feet, shielded cable is recommended.
- Multiple sensors can be parallel-series wired to sense average temperatures in large spaces. See Fig. 2.
- To maintain control accuracy, the number of sensors wired parallel-series must be n^2 (examples: 4, 9, 16).

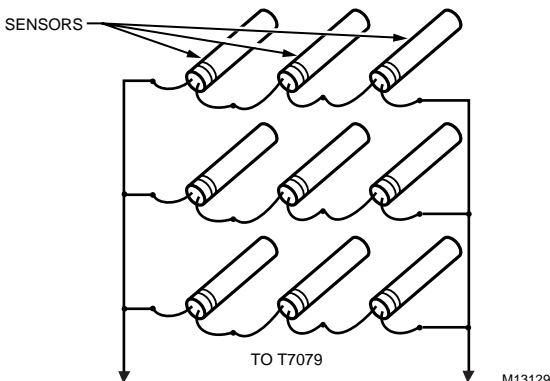

Fig. 2. Parallel-series wiring of sensors.

Sensor Mounting

IMPORTANT

The T7079 is an operation control, not a limit or safety control. If used in applications requiring safety or limit controls, use a separate safety or limit control device in conjunction with the T7079.

Mount the sensor(s) in one of the following manners:

- Hot/cold water sensing: Strap sensor to a pipe or insert in a well (see Fig. 3).
- Space temperature sensing: Mount on a wall or panel (see Fig. 4).
- Duct air sensing: Tape to a standard cap or bulb holder.

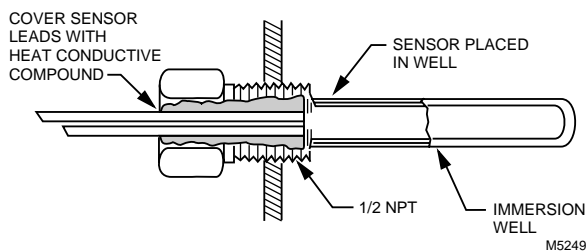

Fig. 3. Sensor inserted in an immersion well.

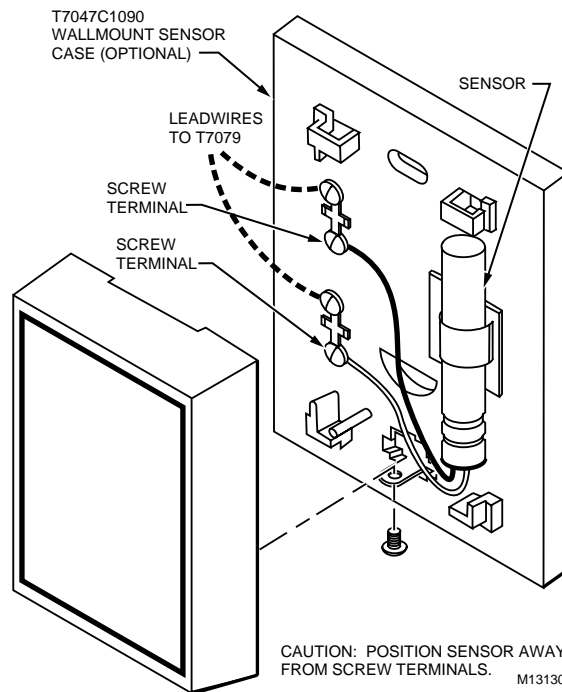

Fig. 4. Wall-mounted sensor.

WIRING

CAUTION

Electrical Shock or Equipment Damage Hazard.
Can shock individuals or short equipment circuitry.
 Disconnect power supply before installation.

Refer to Fig. 5 for locating the appropriate power input, remote sensor input and stage output terminals. To access the terminals, remove the four cover screws and lift off the cover.

Refer to Fig. 6 and 7 for typical wiring.

IMPORTANT

Erratic temperature readings from the Sensor can be caused by poor wiring practices that must be avoided to ensure proper operation:

1. Do not route the temperature sensor wiring with building power wiring.
2. Do not locate the temperature sensor wiring next to control contactors.
3. Do not locate the temperature sensor wiring near electrical motors.
4. Do not locate the temperature sensor wiring near welding equipment.
5. Make sure good mechanical connections are made to both the sensor and the control.
6. Use 90°C copper wire.

NOTES:

1. The larger conduit knockout on the enclosure bottom is for line-voltage applications.
2. The smaller knockout on the enclosure bottom is for low-voltage applications.
3. The sensor knockout is at the enclosure top.

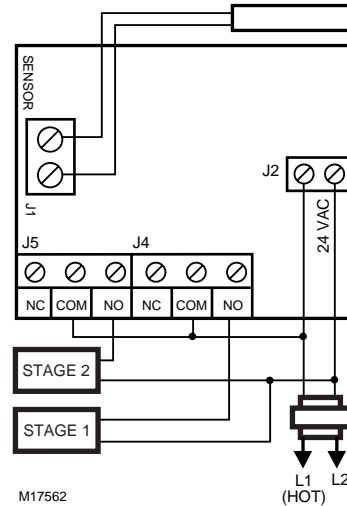
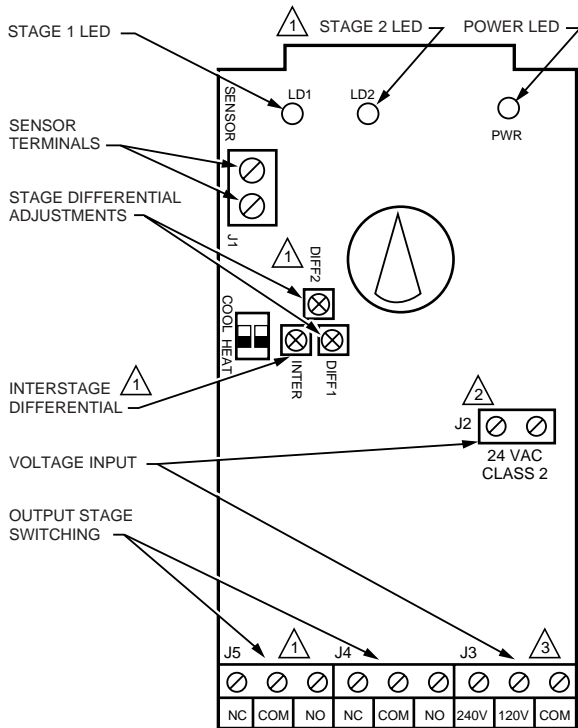

Fig. 6. Typical low-voltage (24 Vac) wiring application.



- 1 TWO-STAGE MODELS ONLY.
- 2 LOW-VOLTAGE MODELS ONLY.
- 3 LINE-VOLTAGE MODELS ONLY.

Fig. 5. Board layout for T7079.

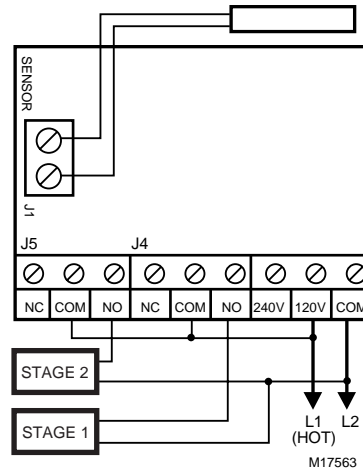

Fig. 7. Typical line-voltage (120 Vac) wiring application.

OPERATION

Control Algorithm

On/Off Control

When used in heating mode, the relay is:

- Energized at setpoint minus differential on temperature fall.
- De-energized at setpoint on temperature rise.

When used in cooling mode, the relay is:

- Energized at setpoint plus differential on temperature rise.
- De-energized at setpoint on temperature fall.

NOTE: Each stage LED lights when its stage is energized.
The power LED lights when the controller is connected to 120/230 or 24 Vac.

Differential (Stage and Interstage) Adjustment

The stage and interstage differential values are adjusted using the internal potentiometers (see Fig. 8). Values for setting are marked on the inside cover:

- Minimum stage differential (DIFF1 or DIFF2): 1°F.
- Interstage differential: 0°F to 35°F.

NOTES:

- Actual minimum differential is typically between 1°F and 4°F. It is influenced by device tolerances and the rate of temperature change.
- The setpoint knob setting is the stage 1 setpoint.
- The stage 2 setpoint is created using the stage 1 setpoint and the interstage differential:
 - When stage 2 is used for heating, the stage 2 setpoint is the stage 1 setpoint minus the interstage differential.
 - When stage 2 is used for cooling, the stage 2 setpoint is the stage 1 setpoint plus the interstage differential.

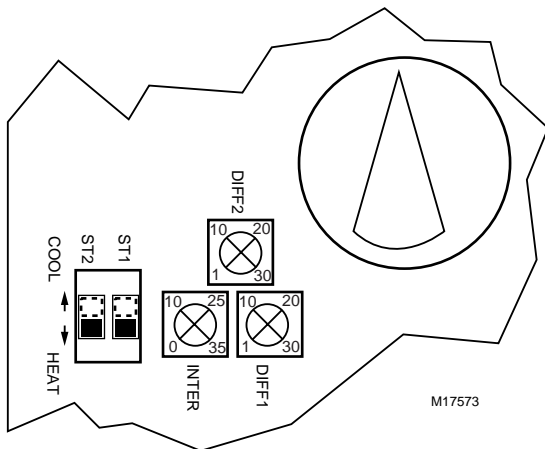

Fig. 8. Adjustments (potentiometers and switches).

TWO-STAGE HEAT

1. Set ST1 and ST2 switches to HEAT.
2. Set interstage (INTER) and differential (DIFF1, DIFF2) to desired settings.
3. Position the setpoint knob at the setting for stage 1.

TWO-STAGE COOL

1. Set ST1 and ST2 switches to COOL.
2. Set interstage (INTER) and differential (DIFF1, DIFF2) to desired settings.
3. Position the setpoint knob at the setting for stage 1.

ONE-STAGE HEAT/ONE-STAGE COOL

1. Set ST1 switch to HEAT and ST2 switch to COOL.
2. Set interstage (INTER) and differential (DIFF1, DIFF2) to desired settings.
3. Position the setpoint knob at the setting for stage 1.

NOTE: See Fig. 9 for an example setup.

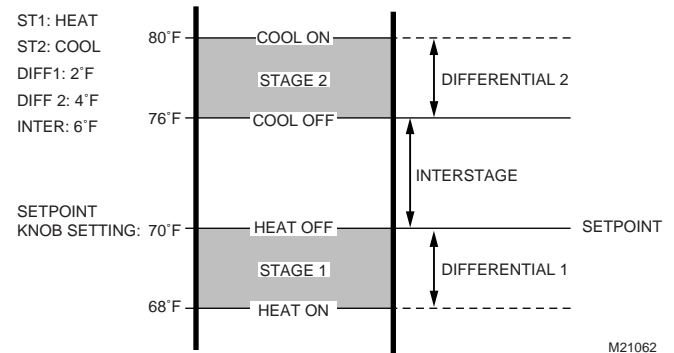

Fig. 9. Example one-stage heat/one-stage cool setup.

NOTE: Keep in mind that, based on the terminal board labels, the stage 1 relay is J4; the stage 2 relay is J5.

CHECKOUT



CAUTION

Compressor Damage Possible.

Rapid cycling can damage compressor and overload electrical circuits.

When controlling a compressor, allow at least 5 minutes between cycles to equalize internal pressure.

NOTES:

- Checkout will depend on the type of hookup and controlled equipment.
- Keep in mind that, based on the terminal board labels, the stage 1 relay is J4; the stage 2 relay is J5.

With the controller installed and wired, use the following procedure:

1. Verify all settings.
2. Apply power.
3. Check for proper equipment response.
 - a. Cooling applications: turn the setpoint knob counterclockwise until the stage LED lights.
 - b. Heating applications: turn the setpoint knob clockwise until the stage LED lights.

NOTE: The stage LED indicates a call for cool/heat. When it lights, the equipment should respond.

Honeywell

Automation and Control Solutions

Honeywell International Inc.
1985 Douglas Drive North
Golden Valley, MN 55422

Honeywell Limited-Honeywell Limitée
35 Dynamic Drive
Scarborough, Ontario
M1V 4Z9

Honeywell International

Control Products
Honeywell Building
17 Changi Business Park Central 1
Singapore 486073

Honeywell Europe S.A.

3 Avenue du Bourget
1140 Brussels
Belgium

Honeywell Latin American Region

480 Sawgrass Corporate Parkway
Suite 200
Sunrise FL 33325

