



ELECTRIC THERMOSTATS - LIMIT CONTROLS

5225 Series

The Robertshaw® 5225 Series Limit Control is designed for any appliance where temperature protection is needed. All 5225 Series controls are non-adjustable, factory calibrated, and feature negative biased power element diaphragms. The 5225 Series is a proven safety control for commercial and specialty applications. They are available in automatic or manual reset versions with temperature settings from 425°F to 600°F (218°C to 316°C).

Features and Benefits

- Bulb and capillary assemblies available in nickel plated copper
- Available in manual reset or automatic operation
- Control function is designed to interrupt power in the appliance circuit at the calibrated temperature



5225-112

Specifications

Part Numbers	Description	Fixed Temperature	Capillary Length	Bulb Size	Mounting Bracket	Stuffing Box
5225-009	LCH Manual Reset Limit Control	450°F (232.222°C)	30"	5/16" x 3-5/8" Nickel	#1	NA
5225-010	LCC Automatic Reset Limit Control	450°F (232.222°C)	60"	3/16" x 4-7/8" Nickel	#1	3/8"
5225-047	LCH Manual Reset Limit Control	450°F (232.222°C)	24"	3/16" x 7-5/8" Nickel	#1	3/8"
5225-054	LCH Manual Reset Limit Control	440°F (226.667°C)	30"	1/4" x 4-7/8" Nickel	#7	Panel Nut
5225-112	LCH Manual Reset Limit Control	450°F (232.222°C)	30"	1/4" x 4-7/8" Nickel	#3	1/4"
LCCM-33-036-00-00 (SA)	LC Series High Limit Safety Thermostat - Contacts NC SPDT	232°C (449.6°F)	1.524mm	4.76mm x 124mm	NA	NA
LCHM-24-036-00-00 (SA)	LC Series High Limit Safety Thermostat - Contacts NC SPST	227°C (440.6°F)	914mm	7.94mm x 92mm	NA	NA

Model	Description	UL Rating	CSA Rating	European
LCH	SPST - Break on Temperature Rise Manual Reset. Type M2*	30 A, 250V AC @ 125-480 V AC 35 VA PD @ 24 V, 60 Hz	30 A @ 125-480V AC	30 A @ 480V AC
LCC	SPDT - Make and / or Break on Temperature Rise. Automatic Reset	25 A, 250 VA @ 125-480 V, 60 Hz 35 A @ 24V AC	25 A, 250 V AC @ 125-480V AC 35 VA PD @ 24 V, 60 Hz	25 A @ 480V AC





Product Drawings

Product Dimensions - Dimensions are inches and [millimeters].

MODEL LCC

FRONT VIEW

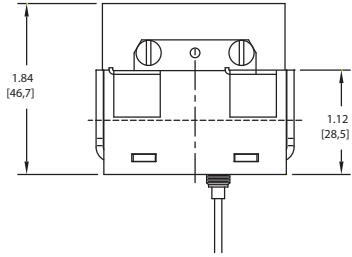

MODEL LCC

TOP VIEW

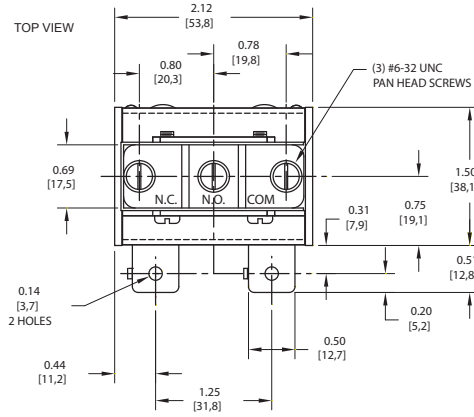

MODEL LCH

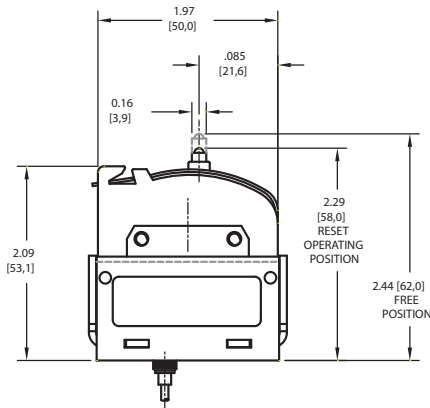

MODEL LCH

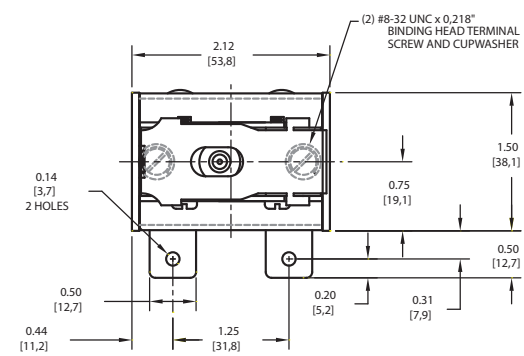

MODEL LCH

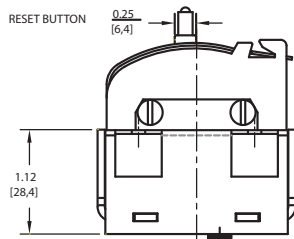

Panel Nut



MODEL LCH

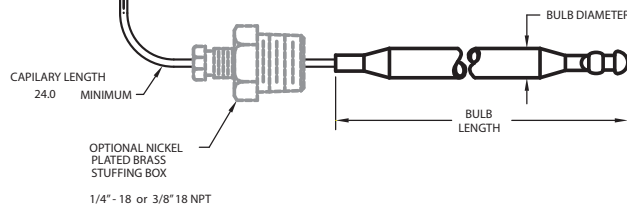
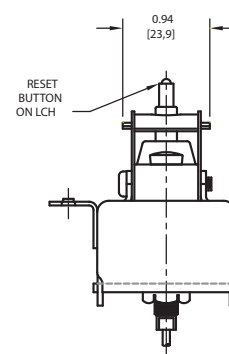



Product Drawings

Mounting Bracket Types

Type #1

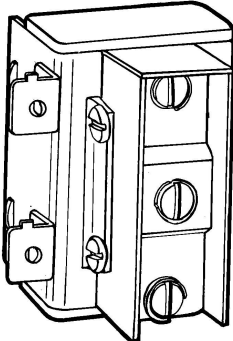

Type #3

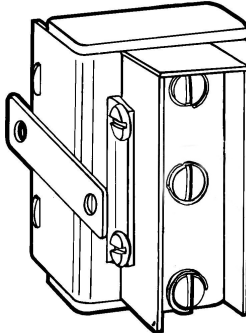

Type #7

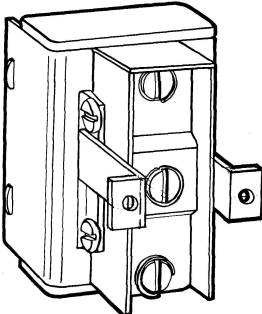

Robertshaw[®]

1 Year
Limited
Warranty

